

AF-10 EVOLUTION

MÁQUINAS PARA LA RECOLECCIÓN DE FRUTA
MACHINES FOR FRUIT HARVESTING
MACHINES POUR LA RÉCOLTE DE FRUITS

 argiles

ES Transporte individual de la fruta. De 260 a 340 Kg. / Persona / Hora con la máxima calidad

EN Individual transport of the fruits. From 260 to 340 Kg. / Person / Hour with the maximum quality

FR Transport individuel des fruits. De 260 à 340 Kg. / Personne / Heure avec la qualité maximale



10

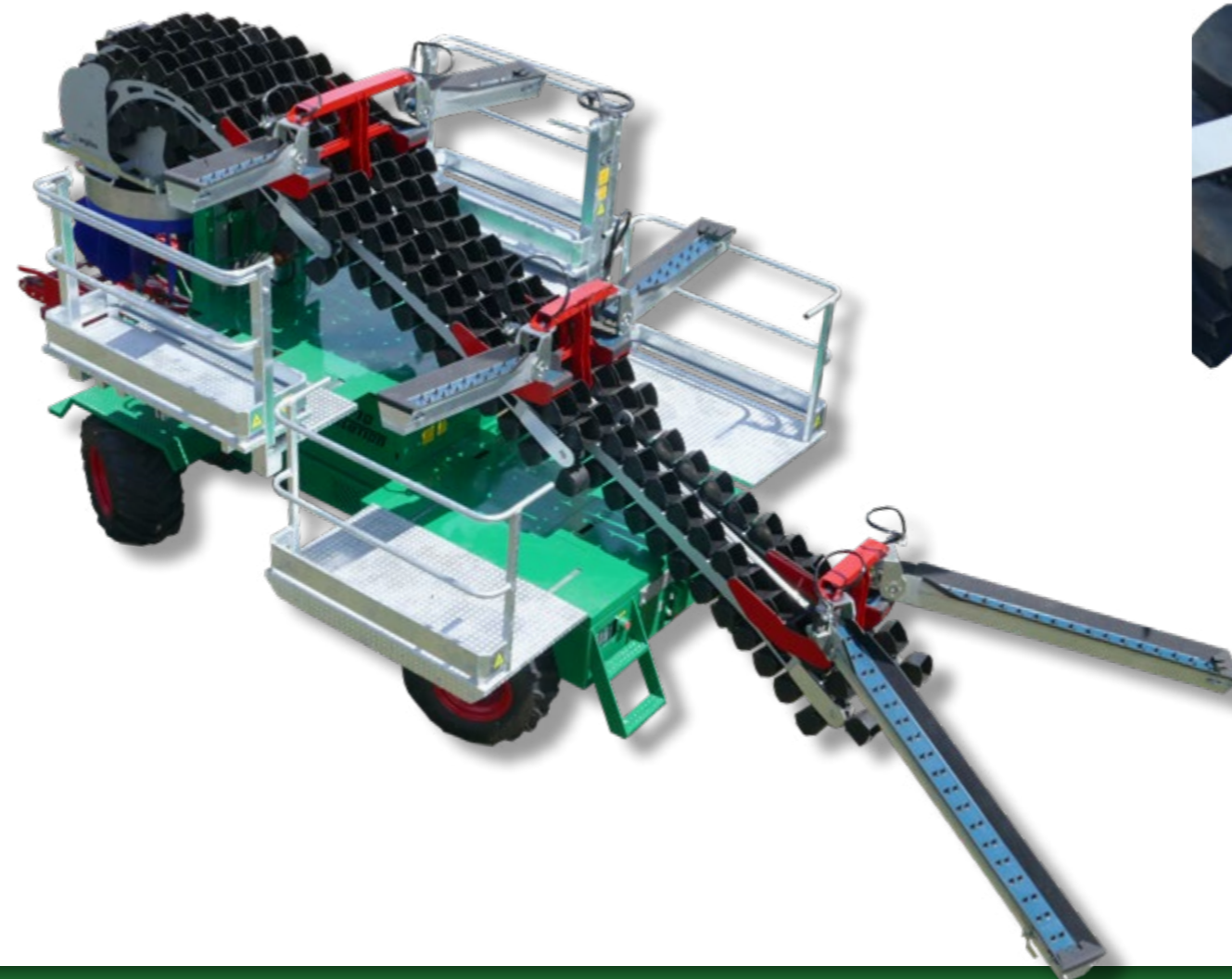
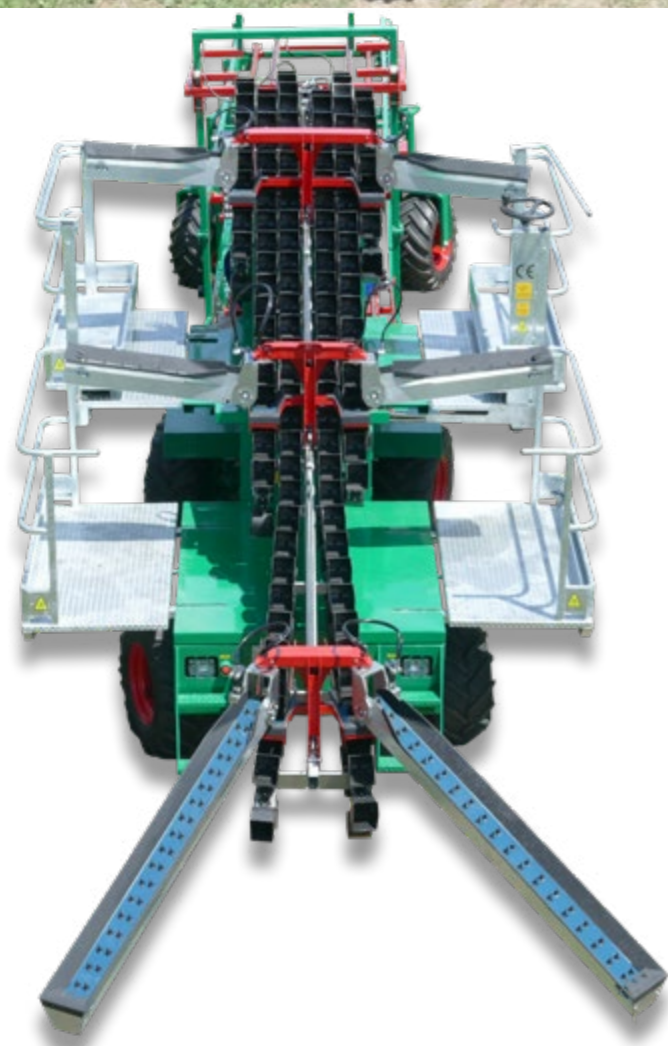

11





■ Los brazos, por su diseño, permiten un ángulo de trabajo de 180°, dejando siempre los frutos de uno en uno al centro de los cazos, y muy fáciles de manejar. Los de la parte delantera permiten un giro de 270°, lo que facilita la entrada en las hileras sin tener que plegarlos y depositar fruta en ellos desde el primer momento.

■ The arms, by design, allows working angle of 180 degrees, always leaving the fruits one by one to the centre of the bowls, and very easy to handle. Those in the front allow a rotation of 270° which facilitates the entry into the rows without having to fold them and place fruit in them from the start.

■ Les bras par sa conception, permettent un angle de travail de 180°, en laissant toujours les fruits un par un au centre des godets, et très facile à manipuler. Les bras de devant permettent une rotation de 270°, ce qui facilite l'entrée dans les lignes sans avoir à plier, et permet de mettre les fruits dès le premier moment.

■ Cada brazo deja el fruto en su línea de cazos, y cada una de las 6 líneas, lo deja en seis puntos diferentes dentro del diámetro de 880 mm. del giratorio de llenado. Finalmente se reparte entre 14 tapices dentro del palot, garantizando un nivel de llenado óptimo.

■ Each arm leaves the fruits in its line of cups, and each of the 6 lines, leaves the fruits in six different points inside the 880mm. diameter rotary filler. Finally the fruits are distributed among 14 tapestries inside the bin, with the guarantee of a perfect filling level.

■ Chaque bras laisse les fruits dans sa ligne de godets, et chacune des 6 lignes laisse les fruits en six points différents à l'intérieur de le diamètre du 880 mm. de le remplissage rotatif. Enfin, 14 tapis sont responsables de laisser les fruits sur le palox, garantissant un niveau de remplissage optimal.



ES

Modelo AF-10 EVOLUTION.
Para la asistencia a la recolección de la fruta, con el innovador sistema único en el mundo de transporte individual de la fruta con cazos, evitando cualquier tipo de golpe, rozadura y pinchazos de mangos entre las frutas.

EN

AF-10 EVOLUTION model.
For the assistance in collecting fruits, with the innovative unique system in the world that transport the fruits individually through rubber bowls, avoiding any kind of shocks, frictions and puncture marks with the fruits.

FR

Modèle AF-10 EVOLUTION.
Pour l'assistance dans la récolte des fruits, avec le système unique et novateur dans le monde qui transportent les fruits individuellement par bols en caoutchouc, en évitant toute forme de chocs, frictions et de ponctions avec les fruits.

12



13

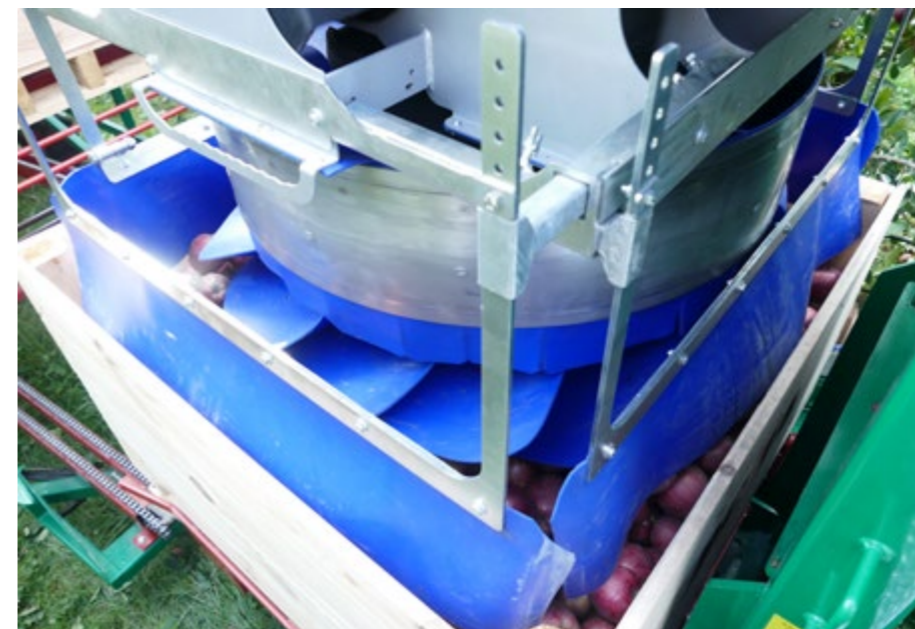

ES

AF-10 ESTÁNDAR

- Motor Kubota 4 cil. 35 CV, refrigerado por agua
- Transmisión hidrostática
- 2 Velocidades, de 0 a 14 Km/h
- Sistema de frenos en negativo. Bloqueo automático motor parado o en neutro
- Dirección Servo-Hidráulica
- 2 Ruedas Motrices y 2 Ruedas Direccionales Laterales 10.75x15.3
- Plataformas laterales hidráulicas, 2 niveles, accionadas por radiocontrol (1)
- Puesto de conducción fijo a la plataforma (2)
- Equipo de recolección con cazos
- Soporte de los brazos regulable arriba / abajo (3)

Remolque porta-palots completo con 8 maniobras hidráulicas:

- Nivel superior (palots vacíos) con simple fila de cadenas
- Nivel inferior (palots llenos) con doble fila de cadenas
- Ruedas direccionales 7.00 / 12

EN

AF-10 STANDARD

- KUBOTA motor 4 cylinders 35 HP, cooled by water
- Hydrostatic transmission
- 2 speeds, from 0 to 14 Km/h
- Negative brake system. The machine stops automatically when engine off and in neutral
- Hydraulic servo steering
- 2 Wheel drive 10.75/15.3
- 2 Wheel steering 10.75/15.3
- Hydraulic lateral platforms, 2 levels, remote controlled (1)
- Steering column fixed to the platform (2)
- Equipment of Harvesting with bowls
- Adjustable arm support up / down (3)

Bin Trailer with 8 Hydraulic Maneuvers:

- Bin trailer upper part (Empty Bins) with Simple Chain
- Bin Trailer bottom part (Full Bins) with Double row of Chains
- 2 Wheels steering 7.00 / 12

FR

AF-10 STANDARD

- Moteur KUBOTA 4 cil. 35HP, refroidi par eau
- Transmission hydrostatique
- 2 Vitesses, de 0 a 14 km/h
- Système de freinage négative. La machine s'arrête automatiquement quand le moteur est éteint et au point mort
- Direction servo-hydraulique
- 2 Roues motrices 10.75/15.3
- 2 Roues directionnelles latérales 10.75/15.3
- Plates-formes hydrauliques latérales, 2 niveaux, télécommandé (1)
- Colonne de direction fixée à la plate-forme (2)
- Groupe de cueille avec godets
- Supporte des bras réglable haut / bas (3)

Remorque porte-palots complet de 8 manoeuvres hydrauliques:

- Niveau inférieur (palots remplis) avec double pose de chaînes
- Niveau supérieur (palots vides) avec chaînes (simple pose)
- 2 Roues directionnelles 7.00 / 12

Tecnología de última generación con Guiado por Ultrasonido.

Latest generation technology with Guided by Ultrasound System

Technologie de dernière génération avec le système guidée par Ultrasons

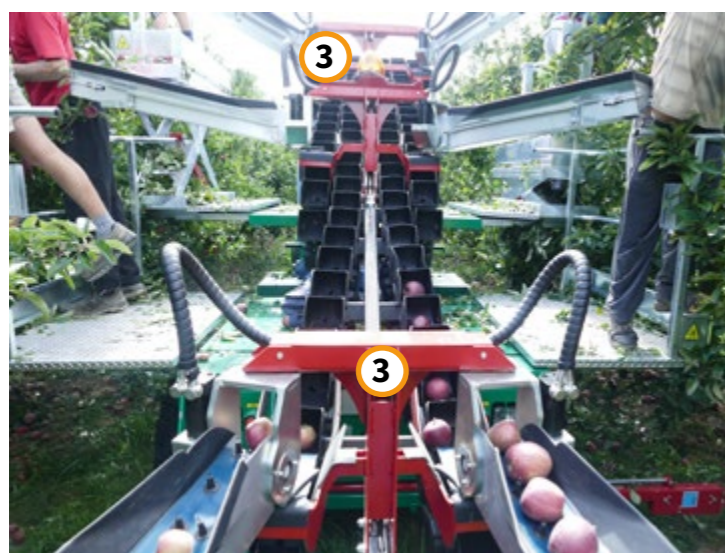

AF-10 EVOLUTION Especificaciones técnicas / Technical specifications / Spécifications techniques

Peso Total en vacío (Tara) / Total Weight (Tare) / Poids Total en vide (Tare)	4.100 kg
Masa Máxima Autorizada / Gross Vehicle Weight Rating / Masse Maximale Autorisée	5.000 kg
Medidas ruedas / Wheels dimensions / Mesure roues	800 x 230 / 800 x 410 mm.
Ancho entre centro ruedas / Width between Wheels Center / Largeur dentre roues	1.500mm.
Capacidad depósito gasoil / Diesel tank Capacity / Capacité réservoir gazole	110 lts.
Capacidad depósito aceite / Oil tank Capacity / Capacité réservoir d'huile	110 lts.
Velocidad máxima / Maximum Speed / Vitesse maximale	12 / 14 Km/h
Radio de giro con 1 eje / Turning Radius with 1 Axle / Rayon de virage avec 1 axe	Interior: 4 mts. / Exterior: 5.8 mts.
Radio de giro con 2 ejes / Turning Radius with 2 Axles / Rayon de virage avec 2 axes	Interior: 2 mts. / Exterior: 3.8 mts.
Pendiente máxima / Maximum inclination / Suspens maximale	40%
Homologación CE / CE Approval / Homologation CE	Si / Yes / Oui

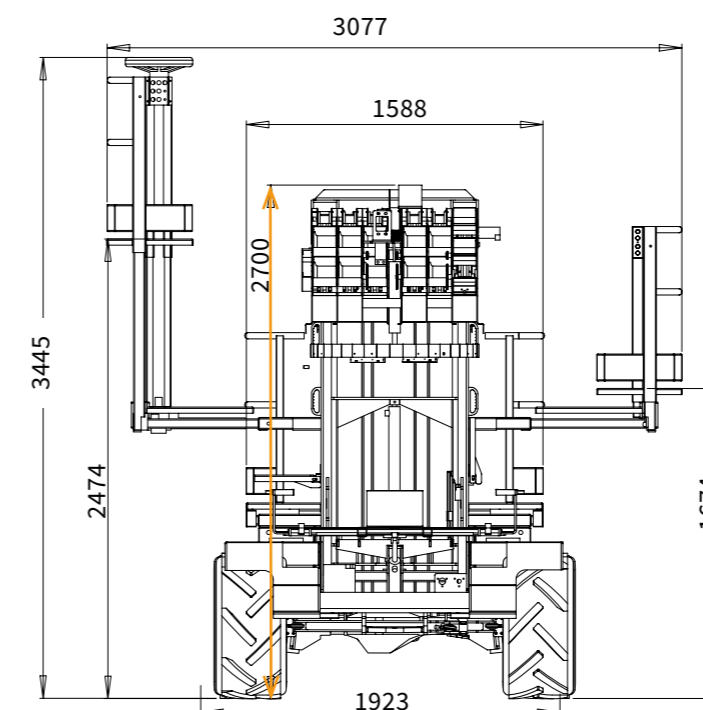
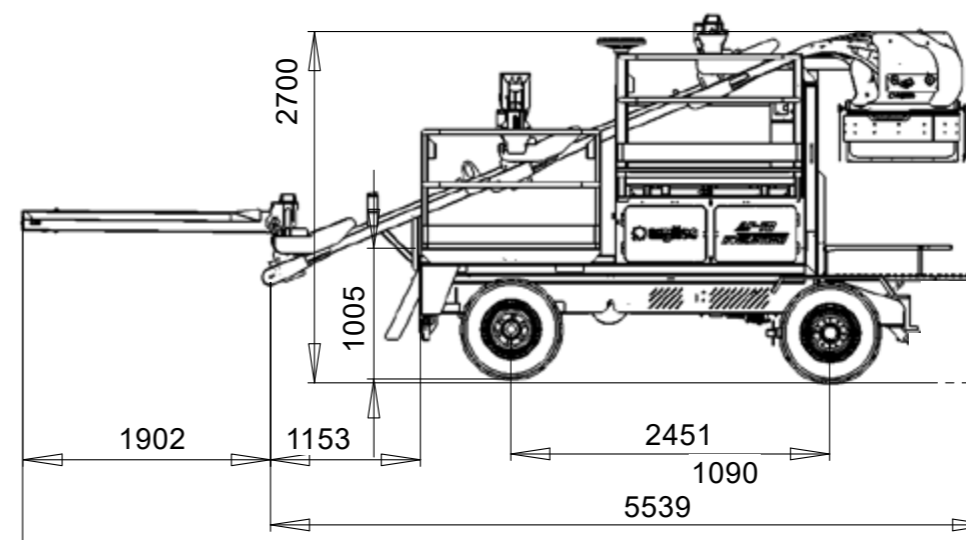

- Contenedor para fruta de industria
- Container for industry fruit
- Récipient pour fruits d'industrie





AF-10 EVOLUTION

MÁQUINAS PARA LA RECOLECCIÓN DE FRUTA
MACHINES FOR FRUIT HARVESTING
MACHINES POUR LA RÉCOLTE DE FRUITS

 argiles



-  Plataformas superiores hidráulicas con tijera
-  Upper platforms with scissor hydraulic displacement
-  Plates-formes supérieures hydrauliques avec ciseaux

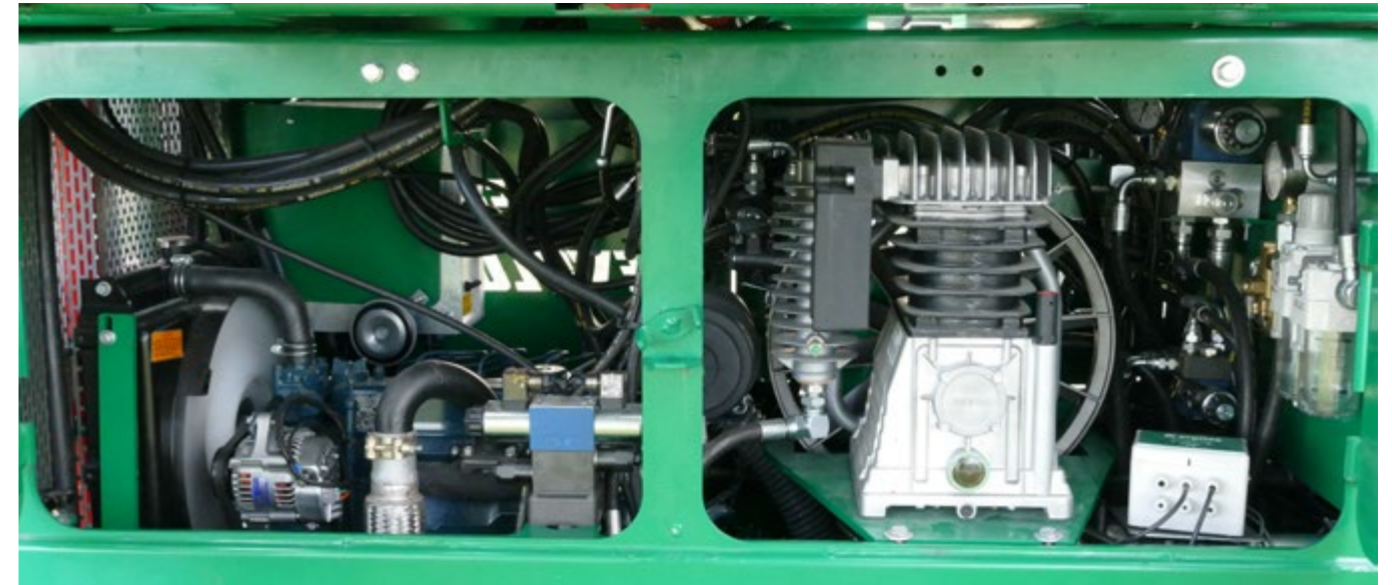

-  Acceso al Motor
-  Access to the Motor
-  Accès au Moteur
-  Compresor de Poda
-  Pruning Compressor
-  Compresseur de Taille



-  Sistema Hidráulico
-  Hydraulic System
-  Système Hydraulique
-  Sistema Eléctrico
-  Electric System
-  Système Électrique



16

17



AF-9 / AF-10 EVO. TRAILER

MÁQUINAS PARA LA RECOLECCIÓN DE FRUTA
MACHINES FOR FRUIT HARVESTING
MACHINES POUR LA RÉCOLTE DE FRUITS

 argiles

- REMOLQUE PORTA-PALOTS COMPLETO CON 8 MANIOBRAS HIDRÁULICAS POR RADIO CONTROL DE SERIE
- BIN TRAILER FULL EQUIPED WITH 8 HYDRAULIC MANEUVERS BY RADIO CONTROL AS STANDARD EQUIPMENT
- REMORQUE PORTE-PALOX COMPLÈTE AVEC 8 MANŒUVRES HYDRAULIQUES PAR RADIOCOMMANDE DE SÉRIE

