

AF-9 EVOLUTION

MÁQUINAS PARA LA RECOLECCIÓN DE FRUTA
MACHINES FOR FRUIT HARVESTING
MACHINES POUR LA RÉCOLTE DE FRUITS

 argiles

● EL MODELO AF-9 EVOLUTION ES EL SUSTITUTO DEL AF-8. INCORPORA EL SISTEMA DE RECOLECCIÓN CON DOBLE CANAL PRINCIPAL, LOS 3 BRAZOS DE CADA LADO DEJAN LA FRUTA EN SU CORRESPONDIENTE CANAL. Y JUNTO CON LOS BRAZOS MÁS ANCHOS, EL RENDIMIENTO POR PERSONA / HORA AUMENTA CONSIDERABLEMENTE AL DEL AF-8. ES INDICADO PARA LAS VARIETADES DE FRUTA MENOS DELICADAS.

● THE AF-9 EVOLUTION MODEL IS THE SUBSTITUTE OF THE AF-8. INCORPORATES THE DOUBLE MAIN TAPESTRY COLLECTION SYSTEM, THE 3 ARMS OF EACH SIDE LEAVE THE FRUIT IN ITS CORRESPONDING TAPESTRY. AND TOGETHER WITH THE WIDEST ARMS, THE PERFORMANCE PER PERSON / HOUR INCREASES CONSIDERABLY THROUGH THE AF-8. IT IS INDICATED FOR LESS DELICATE FRUIT VARIETIES.

● LE MODÈLE AF-9 EVOLUTION EST LE SUBSTITUT DE L'AF-8. COMPREND LE DOUBLE SYSTÈME DE TAPIS PRINCIPALE, LES 3 BRAS DE CHAQUE CÔTÉ LAISSENT LE FRUIT DANS SA TAPIS CORRESPONDANTE. ET AVEC LES BRAS LES PLUS LARGES, LA PERFORMANCE PAR PERSONNE / HEURE AUGMENTE DE MANIÈRE CONSIDÉRABLE À L'AF-8. IL EST INDIQUÉ POUR LES VARIÉTÉS DE FRUITS MOINS DÉLICATES.



18

19



AF-9 / AF-10 EVO. TRAILER

MÁQUINAS PARA LA RECOLECCIÓN DE FRUTA
MACHINES FOR FRUIT HARVESTING
MACHINES POUR LA RÉCOLTE DE FRUITS

 argiles

- REMOLQUE PORTA-PALOTS COMPLETO CON 8 MANIOBRAS HIDRÁULICAS POR RADIO CONTROL DE SERIE
- BIN TRAILER FULL EQUIPED WITH 8 HYDRAULIC MANEUVERS BY RADIO CONTROL AS STANDARD EQUIPMENT
- REMORQUE PORTE-PALOX COMPLÈTE AVEC 8 MANŒUVRES HYDRAULIQUES PAR RADIOCOMMANDE DE SÉRIE

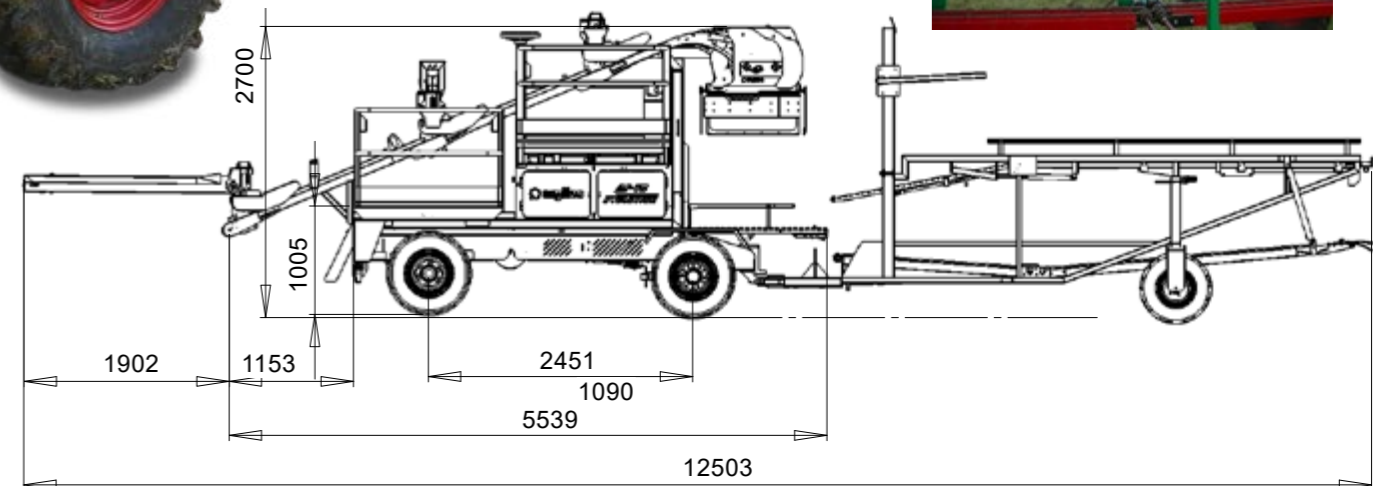

20

21