

JOPER

PORTA-PALETES
FORK-LIFT
ÉLEVATEUR HYDRAULIQUE
PORTA PALETES

PP





● CARACTERÍSTICAS PRINCIPAIS

- Fácil montagem em tratores equipados com sistema hidráulico de 3 pontos.
- Munhões tipo II.
- Estrutura em perfis de aço especiais.
- Mastros com sistema duplex.
- Elevador com 3 movimentos: altura, inclinação e deslocação lateral.
- Circuito hidráulico completo, com centralina de comandos manual e tubos de engate.

EQUIPAMENTO EXTRA

- Aperto de caixas.
- Centralina electrohidráulica.

● MAIN FEATURES

- Easy connection in all tractors equipped with 3 point-hitch hydraulic system.
- Link pins cat. II.
- Structure in special steel profiles.
- Masts with duplex system.
- Elevator with 3 movements: height, inclination and lateral displacement.
- Complete hydraulic system, with central operated by manual commands and fast plugging tubes to the tractor.

EXTRA EQUIPMENT

- Press boxes.
- Electrohydraulic central.

● CARACTÉRISTIQUES PRINCIPALES

- Attelage simple à tous les tracteurs équipés d'un attelage hydraulique à 3 points.
- Axes d'attelage cat. II.
- Structure faite avec des profils en aciers spéciaux.
- Mâts avec système duplex.
- Elevateur avec 3 mouvements: hauteur, inclination et déplacement lateral.
- Système hydraulique complet avec central de commandes manuel et tubes d'engagement rapides au tracteur.

EQUIPMENT EXTRA

- Serre-caisses.
- Centrale electrohydraulique.

● CARACTERÍSTICAS TÉCNICAS

- Facil enganche en tractores equipados com sistema hidráulico de 3 puntos .
- Enganche a 3 puntos cat. II.
- Estructura en perfiles de acero especiales..
- Mástiles con el sistema duplex.
- Elevador con 3 movimientos: altura, inclinación y dislocación lateral.
- Sistema hidráulico completo, con centralina de comandos manual y tubos de enganche rápido al tractor.

EQUIPO ADICIONAL

- Apierto de cajas.
- Centralina electrohidraulica.

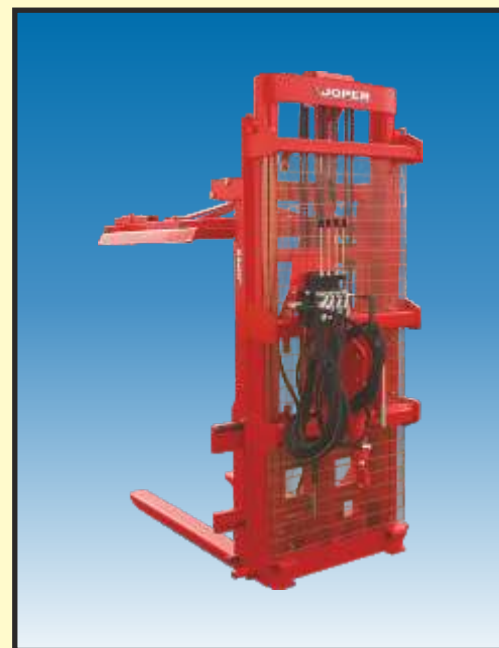
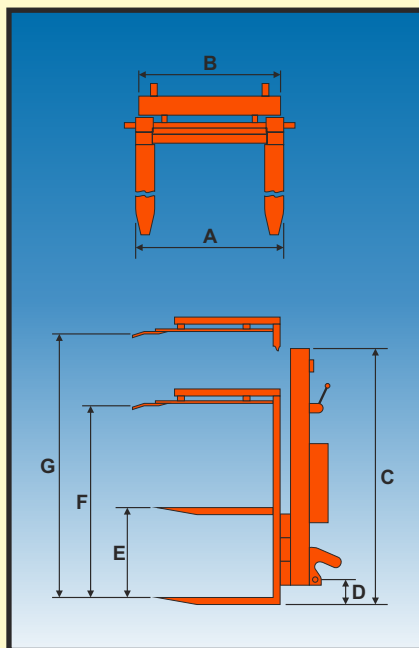
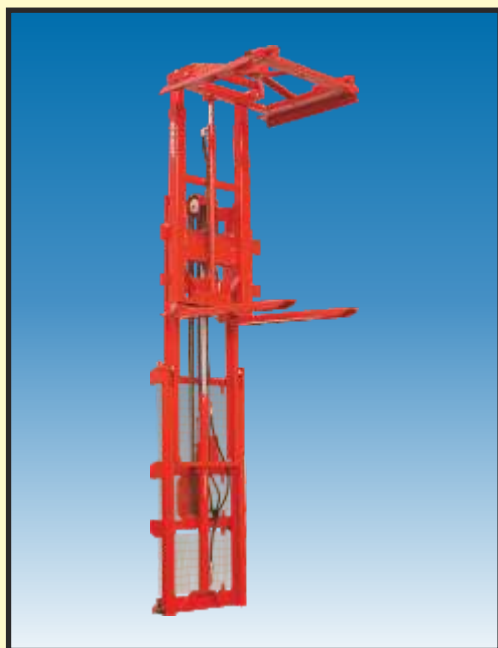

CARACTERÍSTICAS TÉCNICAS - TECHNICAL CHARACTERISTICS - CARACTÉRISTIQUES TECHNIQUES - CARATERISTICAS TÉCNICAS

MODELO MODEL MODÈLE MODELO	CARGA MÁXIMA MAXIMUM LOADING CHARGE CHARGE MAXIMUM CARGA MÁXIMA (Kg)	TOTAL TOTAL TOTAL TOTAL TOTAL (cm)							PESO WEIGHT POIDS PESO (Kg)	
		A	B	C	D	E	F	G	(a)	(b)
PP 15 E 200	1500	70	75	190	43	200	139	340	357	517
PP 15 E 260	1500	70	75	220	43	260	139	400	386	546

(a) - Sem aperto de caixas - Without press-boxes - Sans serre-caisses - Sin apierto de cajas (b) - Com aperto de caixas - With press-boxes - Avec serre-caisses - Con apierto de cajas

Gravuras e dados técnicos sujeitos a alterações sem aviso prévio - Prints and technical data, subject to change without notice - Illustrations et données, soumises à alteration sans pré avis - Graburas e dados técnicos, sujeitos a alteración sin aviso prévio